

ED  **WOOD**
WE ARE OAK.



Content

- 04 About us
- 08 Finger jointed panels
- 22 Solid panels
- 28 3 layer panels
- 30 Engineered panels
- 32 Scantlings
- 34 S4S components
- 36 CNC components
- 38 Thermo products
- 40 Wash basins
- 44 Wall panels
- 46 Cutting boards
- 48 Pellets
- 50 Other services



WE ARE OAK.

EDWOOD IS A FAMILY BASED COMPANY SPECIALISING IN OAK PROCESSING. SET UP IN 1999 AS A SAWMILL PRODUCING OAK FRISAS AND BOARDS FOR FLOORING INDUSTRY. 25 YEARS OF LONG-TERM DEVELOPMENT CREATES ONE OF THE EUROPE'S LEADING MANUFACTURER OF GLUED PANELS IN OAK.

High skilled workers together with keeping whole production cycle (from logs processing into final product's finishing) in own controlled chain generate long term partnership with many markets.

Edwood is a brand of a Polish company that processes oak and - complementarily - other wood species. It is one of the major players on the European market, which,

despite its momentum, has not lost its family character and, most importantly, its artisanal approach to production. Edwood delivers well-chosen products, but above all cares about the quality and closeness of relationships with its partners, supporting the development of their businesses. This is confirmed by long-standing business relationships with most important customers.



EdWood in numbers:

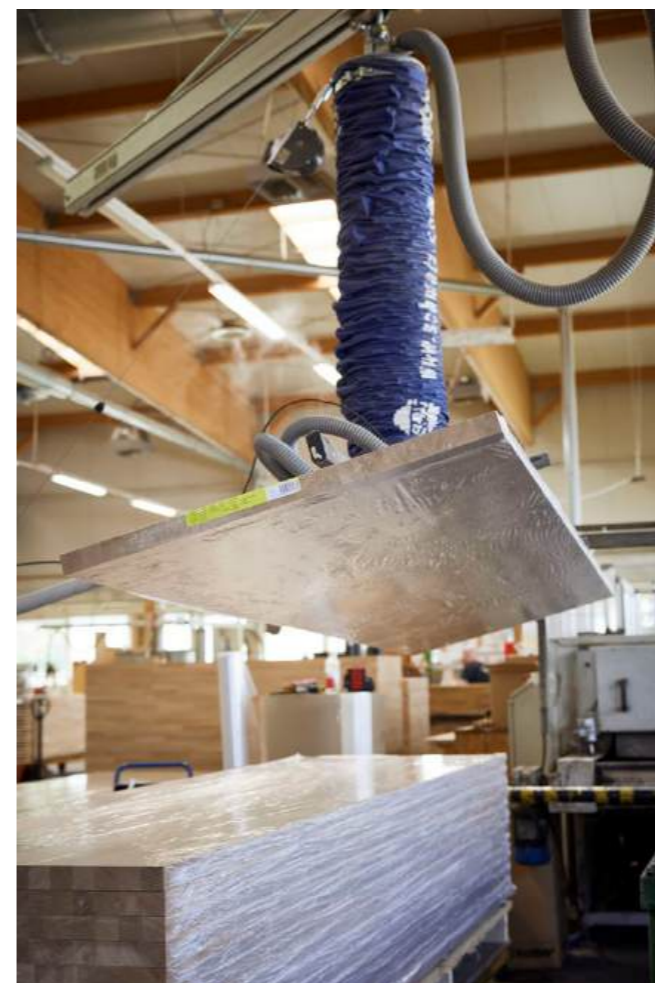
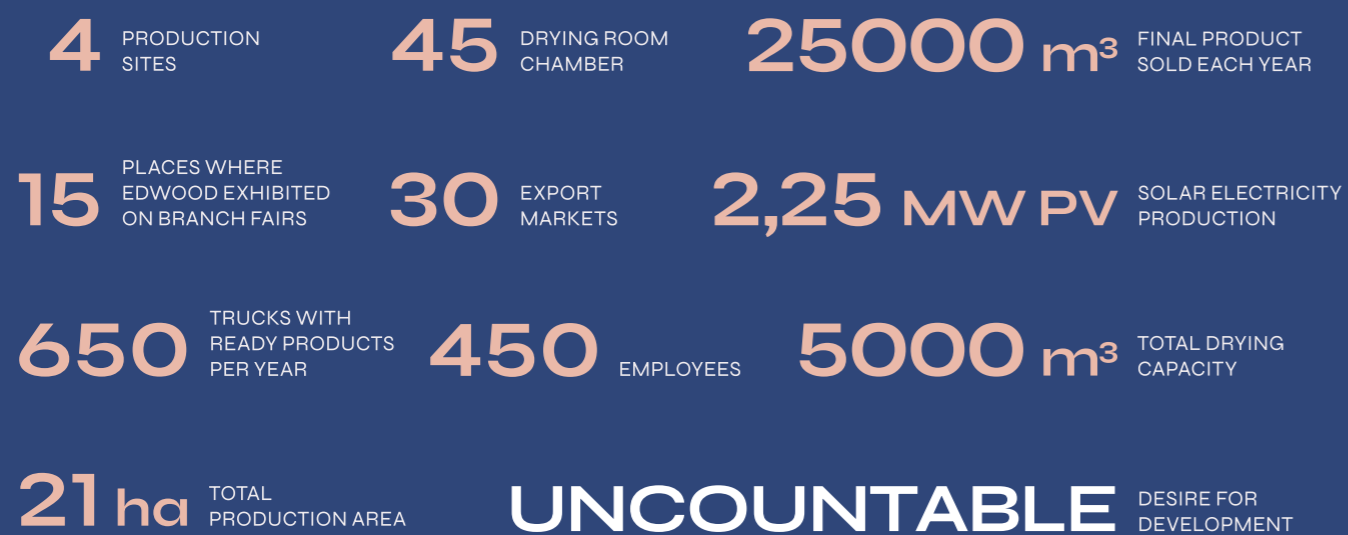

PRODUCTS



Finger jointed panels

Finger jointed panels are composed of short wood pieces glued together lengthwise. This construction gives very high stability of panels. We produce wide range of products in

this group: kitchen worktops, bathroom worktops, shelvings, stair treads, furniture boards, window sills, table tops & legs, cutting boards, wall panels, door frames, etc.



A/B Oak

QUERCUS ROBUR L.

ASSORTMENT DESCRIPTION

THICKNESS	15-45 mm
LENGTH	up to 6100 mm
WIDTH	up to 1300 mm
STAVE	narrow; standard 40-45 mm; wide
GLUING	free from formaldehyde PVE Glue D3 or D4 according to DIN EN 204
MOISTURE	8% +/- 2%
SANDING	grit 120-150

QUALITY DESCRIPTION

A-GRADE / TOP	B-GRADE / REVERSE
<ul style="list-style-type: none">▪ homogenous panel▪ best color matching▪ pin knots allowed▪ no sapwood	<ul style="list-style-type: none">▪ less color matching▪ sound knots up to 20 mm▪ occasionally black or/and open knots up to 10 mm▪ sapwood up to 20% of the total surface allowed maximum 50% of the width of single frisas



B/C Oak

QUERCUS ROBUR L.

ASSORTMENT DESCRIPTION

THICKNESS	15-45 mm
LENGTH	up to 6100 mm
WIDTH	up to 1300 mm
STAVE	narrow; standard 40-45 mm; wide
GLUING	free from formaldehyde PVE Glue D3 or D4 according to DIN EN 204
MOISTURE	8% +/- 2%
SANDING	grit 120-150

QUALITY DESCRIPTION

B-GRADE / TOP	C-GRADE / REVERSE
<ul style="list-style-type: none"> ▪ less color matching ▪ sound knots up to 20 mm ▪ occasionally black or/and open knots up to 10 mm - filled with putty ▪ sapwood up to 20% of the total surface allowed maximum 50% of the width of single frisas 	<ul style="list-style-type: none"> ▪ color variations ▪ unlimited sapwood including stained sapwood ▪ sound/open/black knots ▪ bark pocket / surface cracks: up to 50 mm long, up to 2 mm wide



C/C Oak

QUERCUS ROBUR L.

ASSORTMENT DESCRIPTION

THICKNESS	15-45 mm
LENGTH	up to 6100 mm
WIDTH	up to 1300 mm
STAVE	narrow; standard 40-45 mm; wide
GLUING	free from formaldehyde PVE Glue D3 or D4 according to DIN EN 204
MOISTURE	8% +/- 2%
SANDING	grit 120-150

QUALITY DESCRIPTION

C-GRADE / TOP	C-GRADE / REVERSE
<ul style="list-style-type: none"> ▪ color variations ▪ sapwood including stained sapwood ▪ sound/open/black knots - filled with putty ▪ bark pocket / surface cracks: up to 50 mm long, up to 2mm wide 	<ul style="list-style-type: none"> ▪ color variations ▪ unlimited sapwood including stained sapwood ▪ sound/open/black knots allowed ▪ bark pocket / surface cracks ▪ occasionally wormholes



Rustic A/B Oak

QUERCUS ROBUR L.

ASSORTMENT DESCRIPTION

THICKNESS	15-45 mm
LENGTH	up to 6100 mm
WIDTH	up to 1300 mm
STAVE	narrow; standard 40-45 mm; wide
GLUING	free from formaldehyde PVE Glue D3 or D4 according to DIN EN 204
MOISTURE	8% +/- 2%
SANDING	grit 120-150

QUALITY DESCRIPTION

A-GRADE / TOP	B-GRADE / REVERSE
<ul style="list-style-type: none"> color matching no sapwood sound knots up to 20 mm open/black knots: up to 15 mm - filled with putty total number of knots to be discussed 	<ul style="list-style-type: none"> less color matching sound knots up to 20 mm occasionally black or/and open knots up to 10 mm sapwood up to 20% of the total surface allowed maximum 50% of the width of single frisas



TOP STANDARD LAMELLA
BOTTOM NARROW LAMELLA

White Ash (A/B)

FRAXINUS EXCELSIOR L.

ASSORTMENT DESCRIPTION

THICKNESS	15-45 mm
LENGTH	up to 6100 mm
WIDTH	up to 1300 mm
STAVE	narrow; standard 40-45 mm; wide
GLUING	free from formaldehyde PVE Glue D3 or D4 according to DIN EN 204
MOISTURE	8% +/- 2%
SANDING	grit 120-150

QUALITY DESCRIPTION

A-GRADE / TOP	B-GRADE / REVERSE
<ul style="list-style-type: none"> homogenous white/light color of panel best color matching pin knots allowed 	<ul style="list-style-type: none"> some color variations allowed (white mixed and brownheart) sound knots up to 20mm black open knots up to 10mm



PICTURE NARROW LAMELLA

Natural Ash (B/C)

FRAXINUS EXCELSIOR L.

ASSORTMENT DESCRIPTION

THICKNESS	15-45 mm
LENGTH	up to 6100 mm
WIDTH	up to 1300 mm
STAVE	narrow; standard 40-45 mm; wide
GLUING	free from formaldehyde PVE Glue D3 or D4 according to DIN EN 204
MOISTURE	8% +/- 2%
SANDING	grit 120-150

QUALITY DESCRIPTION

B-GRADE / TOP	C-GRADE / REVERSE
<ul style="list-style-type: none"> evenly mixed colors (white and brownheart) occasionally sound knots up to 20 mm occasionally black open knots up to 10 mm - filled with putty 	<ul style="list-style-type: none"> any color variations sound knots up to 30 mm black open knots up to 20 mm



A/B Beech

FAGUS SYLVATICA L.

ASSORTMENT DESCRIPTION

THICKNESS	18-45 mm
LENGTH	up to 6100 mm
WIDTH	up to 1300 mm
STAVE	narrow; standard 40-45 mm; wide
GLUING	free from formaldehyde PVE Glue D3 or D4 according to DIN EN 204
MOISTURE	8% +/- 2%
SANDING	grit 120-150

QUALITY DESCRIPTION

A-GRADE / TOP	B-GRADE / REVERSE
<ul style="list-style-type: none"> homogenous panel color balanced - light pink/redish color in case of steamed beech light color - unsteamed beech pin knots allowed 	<ul style="list-style-type: none"> color variations sound knots up to 20 mm black/open knots up to 10 mm brown heart up to 25% of the total surface



B/C Beech

FAGUS SYLVATICA L.

ASSORTMENT DESCRIPTION

THICKNESS	18-45 mm
LENGTH	up to 6100 mm
WIDTH	up to 1300 mm
STAVE	narrow; standard 40-45 mm; wide
GLUING	free from formaldehyde PVE Glue D3 or D4 according to DIN EN 204
MOISTURE	8% +/- 2%
SANDING	grit 120-150

QUALITY DESCRIPTION

B-GRADE / TOP	C-GRADE / REVERSE
<ul style="list-style-type: none"> ▪ color variations ▪ sound knots up to 20 mm ▪ black/open knots up to 10 mm - filled with putty ▪ brown heart up to 25% of the total surface 	<ul style="list-style-type: none"> ▪ all color variations ▪ sound knots till 30 mm, open/black knots up to 15 mm ▪ surface cracks: length till 50 mm, width till 2 mm ▪ brown heart and blue stains unlimited



TOP STANDARD LAMELLA
BOTTOM NARROW LAMELLA

A/B European Walnut

JUGLANS REGIA L.

ASSORTMENT DESCRIPTION

THICKNESS	15-45 mm
LENGTH	up to 6100 mm
WIDTH	up to 1300 mm
STAVE	narrow; standard 40-45 mm
GLUING	free from formaldehyde PVE Glue D3 or D4 according to DIN EN 204
MOISTURE	8% +/- 2%
SANDING	grit 120-150

QUALITY DESCRIPTION

A-GRADE / TOP	B-GRADE / REVERSE
<ul style="list-style-type: none"> ▪ dark color balanced typical for wood species - 96 hours steaming time ▪ pin knots + occasionally sound knots up to 10 mm 	<ul style="list-style-type: none"> ▪ color variations ▪ sapwood allowed ▪ sound knots up to 20 mm ▪ occasionally black or/and open knots up to 10 mm



White Maple (A/B)

ACER PSEUDOPLATANUS L.

ASSORTMENT DESCRIPTION

THICKNESS	15-45 mm
LENGTH	up to 6100 mm
WIDTH	up to 1300 mm
STAVE	narrow; standard 40-45 mm
GLUING	free from formaldehyde PVE Glue D3 or D4 according to DIN EN 204
MOISTURE	8% +/- 2%
SANDING	grit 120-150

QUALITY DESCRIPTION

A-GRADE / TOP	B-GRADE / REVERSE
<ul style="list-style-type: none"> homogenous white/light color of panel best color matching pin knots allowed filled with putty 	<ul style="list-style-type: none"> any color variations allowed sound knots up to 30 mm black open knots till 20 mm



PICTURE NARROW LAMELLA

Natural Maple (B/C)

ACER PSEUDOPLATANUS L.

ASSORTMENT DESCRIPTION

THICKNESS	15-45 mm
LENGTH	up to 6100 mm
WIDTH	up to 1300 mm
STAVE	narrow; standard 40-45 mm
GLUING	free from formaldehyde PVE Glue D3 or D4 according to DIN EN 204
MOISTURE	8% +/- 2%
SANDING	grit 120-150

QUALITY DESCRIPTION

B-GRADE / TOP	C-GRADE / REVERSE
<ul style="list-style-type: none"> evenly mixed colors (white and brownheart) occasionally sound knots up to 20 mm occasionally black open knots up to 10 mm - filled with putty 	<ul style="list-style-type: none"> any color variations sound knots up to 30 mm black open knots up to 20 mm



Thermo Ash

FRAXINUS EXCELSIOR L.

ASSORTMENT DESCRIPTION

THICKNESS	18-42 mm
LENGTH	up to 6100 mm
WIDTH	up to 1300 mm
STAVE	narrow; standard 40-45 mm
GLUING	free from formaldehyde PVE Glue D3 or D4 according to DIN EN 204
MOISTURE	8% +/- 2%
SANDING	grit 120-150

QUALITY DESCRIPTION

A-GRADE / TOP	B-GRADE / REVERSE
<ul style="list-style-type: none"> ▪ homogenous panel ▪ color balanced (thanks to thermo treatment process) ▪ pin knots allowed 	<ul style="list-style-type: none"> ▪ color balanced (thanks to thermo treatment process) ▪ sound knots up to 10 mm, pin knots ▪ cracked knots till 10 mm ▪ brown heart up to 5%



Thermo Beech

FAGUS SYLVATICA L.

ASSORTMENT DESCRIPTION

THICKNESS	18-42 mm
LENGTH	up to 6100 mm
WIDTH	up to 1300 mm
STAVE	narrow; standard 40-45 mm
GLUING	free from formaldehyde PVE Glue D3 or D4 according to DIN EN 204
MOISTURE	8% +/- 2%
SANDING	grit 120-150

QUALITY DESCRIPTION

A-GRADE / TOP	B-GRADE / REVERSE
<ul style="list-style-type: none"> ▪ homogenous panel ▪ color balanced (thanks to thermo treatment process) ▪ pin knots allowed 	<ul style="list-style-type: none"> ▪ color balanced (thanks to thermo treatment process) ▪ sound knots up to 10 mm, pin knots ▪ cracked knots till 10 mm ▪ brown heart up to 5%

Solid panels

Solid panels are composed by wooden massive staves, in thicknesses from 15 mm to 45 mm, width up to 1300 mm,

stave from 40 up to 120 mm. Panels are produced for many applications: Table tops and legs, stair treads, worktops.



TOP STANDARD LAMELLA
BOTTOM WIDE LAMELLA

A/B Oak

QUERCUS ROBUR L.

ASSORTMENT DESCRIPTION

THICKNESS	15-45 mm
LENGTH	up to 3000 mm
WIDTH	up to 1300 mm
STAVE	standard 40-50 mm; wide 55-120 mm
GLUING	free from formaldehyde PVE Glue D3 or D4 according to DIN EN 204
MOISTURE	8% +/- 2%
SANDING	grit 120-150

QUALITY DESCRIPTION

A-GRADE / TOP	B-GRADE / REVERSE
<ul style="list-style-type: none"> ▪ homogenous panel ▪ best color matching ▪ pin knots allowed ▪ no sapwood 	<ul style="list-style-type: none"> ▪ less color matching ▪ sound knots up to 30 mm ▪ occasionally black or/and open knots up to 15 mm ▪ sapwood up to 25% of the total surface allowed maximum 50% of the width of a single stave



TOP STANDARD LAMELLA
BOTTOM WIDE LAMELLA

Rustic Oak

QUERCUS ROBUR L.

ASSORTMENT DESCRIPTION

THICKNESS	15-45 mm
LENGTH	up to 3000 mm
WIDTH	up to 1300 mm
STAVE	standard 40-50 mm; wide 55-120 mm
GLUING	free from formaldehyde PVE Glue D3 or D4 according to DIN EN 204
MOISTURE	8% +/- 2%
SANDING	grit 120-150

QUALITY DESCRIPTION

A-GRADE / TOP	B-GRADE / REVERSE
<ul style="list-style-type: none"> color matching pin knots allowed sound knots up to 20-40 mm - determined by single lamella width bark pockets / surface cracks: length till 100 mm, width till 2 mm - filled with putty no sapwood 	<ul style="list-style-type: none"> color variations knots surface cracks: length till 100 mm, width till 2 mm sapwood up to 20%



White Ash (A/B)

FRAXINUS EXCELSIOR L.

ASSORTMENT DESCRIPTION

THICKNESS	18-45 mm
LENGTH	up to 3000 mm
WIDTH	up to 1300 mm
STAVE	standard 40-50 mm; wide 55-120 mm
GLUING	free from formaldehyde PVE Glue D3 or D4 according to DIN EN 204
MOISTURE	8% +/- 2%
SANDING	grit 120-150

QUALITY DESCRIPTION

A-GRADE / TOP	B-GRADE / REVERSE
<ul style="list-style-type: none"> homogenous white/light color of panel best color matching pin knots allowed 	<ul style="list-style-type: none"> some color variations allowed (white mixed and brownheart) sound knots up to 20 mm black open knots up to 10 mm



Natural Ash (B/C)

FRAXINUS EXCELSIOR L.

ASSORTMENT DESCRIPTION

THICKNESS	18-45 mm
LENGTH	up to 3000 mm
WIDTH	up to 1300 mm
STAVE	standard 40-50 mm; wide 55-120 mm
GLUING	free from formaldehyde PVE Glue D3 or D4 according to DIN EN 204
MOISTURE	8% +/- 2%
SANDING	grit 120-150

QUALITY DESCRIPTION

B-GRADE / TOP	C-GRADE / REVERSE
<ul style="list-style-type: none"> ▪ evenly mixed colors (white and brownheart) ▪ occasionally sound knots up to 20 mm ▪ occasionally black open knots up to 10 mm 	<ul style="list-style-type: none"> ▪ color variations allowed ▪ sound knots up to 30 mm ▪ black open knots up to 20 mm

3 layer panels - 100% oak

Extremely stable solid panel, composed by 2 external oak layers and cross laminated core in the middle. Thickness of the top layer: 3-7 mm.

Total thickness of the panel on request, mainly 20 mm. Quality grades of the top face are prepared according to customer requirements (finger-jointed, full staves in AB or rustic grade).

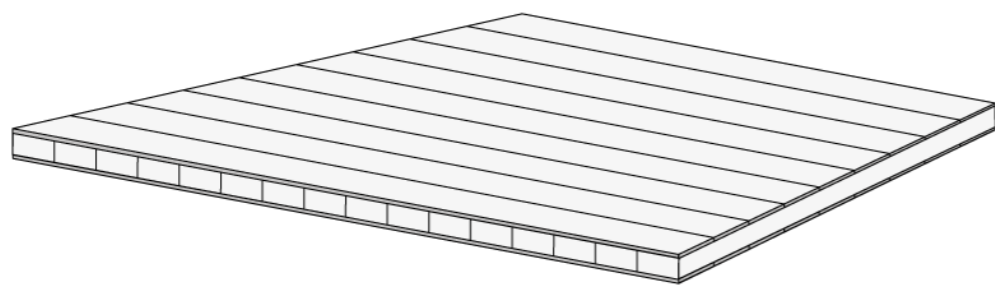

Engineered panels

Engineered products like furniture panels, stairs components etc.
Highly sustainable - ecological products due to low elements
being used in a core.



Scantlings

We produce door and window scantlings for many market leader manufacturers.

Profiles are used for windows and door frames, furniture, legs for tables, stairs. Items are composed by 3 or more layers,

with or without finger-jointed staves. We offer 2 types of scantlings: DKD, KKK.

D – continous lamellas;

K – finger jointed lamellas.

Dimensions, wood species of the product - on customer request.

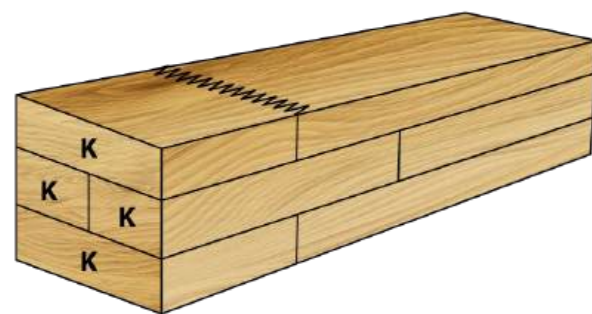

S4S components

4 sides surfaced planned (optionally sanded) solid wood components used predominantly for chairs manufacturers (legs), door manufacturers (tresholds), furniture industries (components for projects).

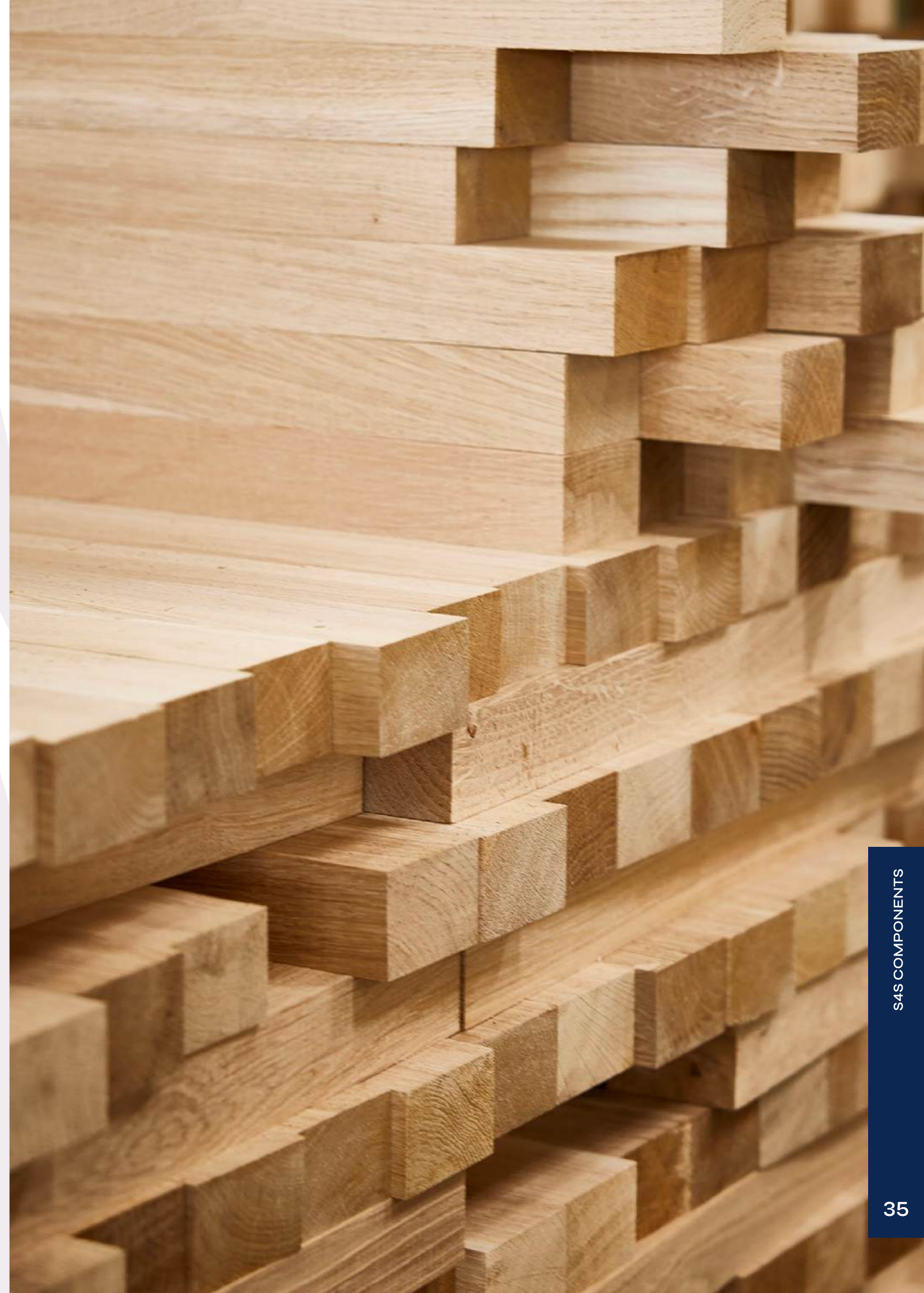

CNC components

We produce some standard products like (flagship) solid wood basins, tables, cutting boards as well as we realise different projects.

Due to fact that our machine can work in 5 Axis and can process maximum dimension 1300x6000 mm we are able to fulfill most challenging products.





Wash basins

For centuries, wood has been used for the production of ships or barrels. Today, it mainly occurs as a raw material for boats, tubs, bathtubs, and washbasins production. Wood gives ordinary objects a beautiful look and warmth. Its unique drawing makes each piece one of a kind. At the same time, with proper processing and impregnation, wood remains untouched and functional for many years.

SVALL washbasins line was implemented by EDWOOD and finally introduced into market in 2022. An unique shape of the item was designed by Martyna Piaściak.

Proper wood selection and lasting construction make SVALL washbasins

extremely solid and at the same time light and sophisticated. The long-term production process of the goods consists of many stages like: wood drying, cutting, gluing the single wood lamellas into solid piece, computer numerical process, oiling and hand finishing process.

Washbasins are available in various types of hardwood species like white oak, American black walnut, ash and maple.

Products are waterproof and easy to handle during the cleaning process. Surface refresh and scratches renovation can be done easily by customer at home, just using the soft material and recommended oil for wood protection.

Our products have been awarded in the following competitions:



DIMENSIONS OF BASIC MODELS

MODEL	DIMENSIONS	WOOD SPECIES
Svall	560x420x100 mm	<ul style="list-style-type: none"> ▪ European oak ▪ American walnut
Angular	560x430x120 mm	<ul style="list-style-type: none"> ▪ Ash ▪ Maple
Wave	500x400x100 mm	

MODELS



WOOD SPECIES / All of our products are made of 100% solid wood.

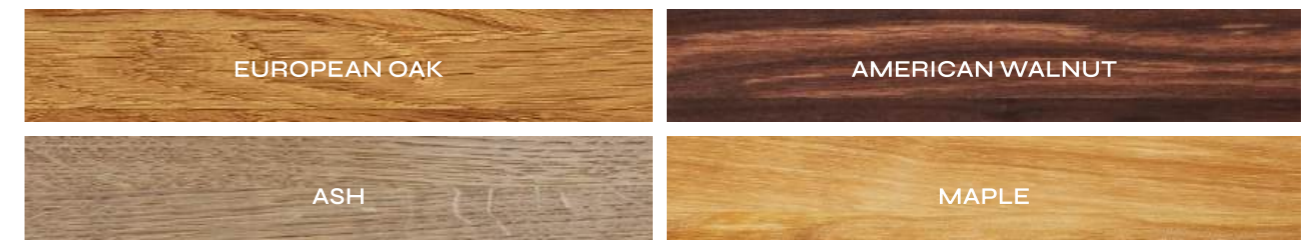

Wall panels



QUALITY STANDARD

The majority of purchased wood is certified according PEFC or FSC standards.

SLATS / WOOD SPECIES

Solid oak, ash, maple, walnut in fingerjoined technology. The surfaces can be finished with oil or lacquer.

	OIL	LAQUER		
Premium oak	X*	X		
Natural oak	X		NATURAL	WALNUT
Rustic oak	X			
Maple		X		
Natural ash		X	BLACK	WHITE
European walnut	X	X		

*(colors: natural, white, walnut or black)

WALL PANEL DIMENSIONS

3000 mm x 600 mm x 30 mm (PET felt + 9 wooden slats)
 2400 mm x 600 mm x 30 mm (PET felt + 9 wooden slats)



PREMIUM OAK
natural oil



PREMIUM OAK
natural oil



PREMIUM OAK
natural oil



PREMIUM OAK
natural oil



PREMIUM OAK
natural oil



PREMIUM OAK
natural oil

BACK PLATE

Our panels are made of recycled PET felts (come from plastic bottles) with 9 mm thickness. Ask us about available colors of the PET felts.

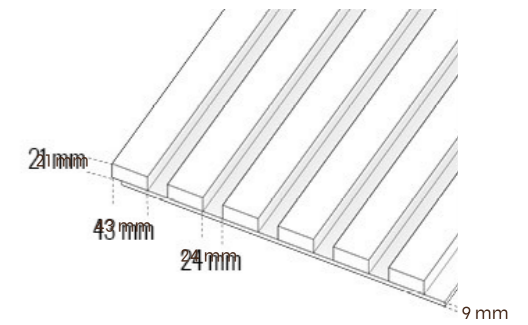

PROFILE

TILT



BASIC

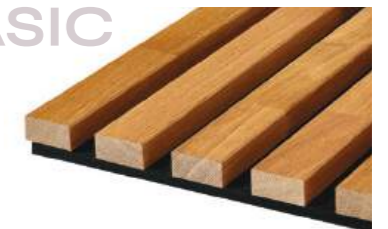

BOW



100%
SOLID WOOD

ACOUSTIC
(1-RI: 0,94)

Cutting boards



Other services

Cut to size, oiling (preoiling and hartwax oiling), lacquering, edge profiling.





Pol-Kres Edwood Sp. z o.o.

Łomaska 86

Biała Podlaska, 21-500

POLAND

CONTACT – ORDERS

edwood@edwood.pl

+48 83 3423606